

FR HIGH RANGE COMPOUND SWITCHES

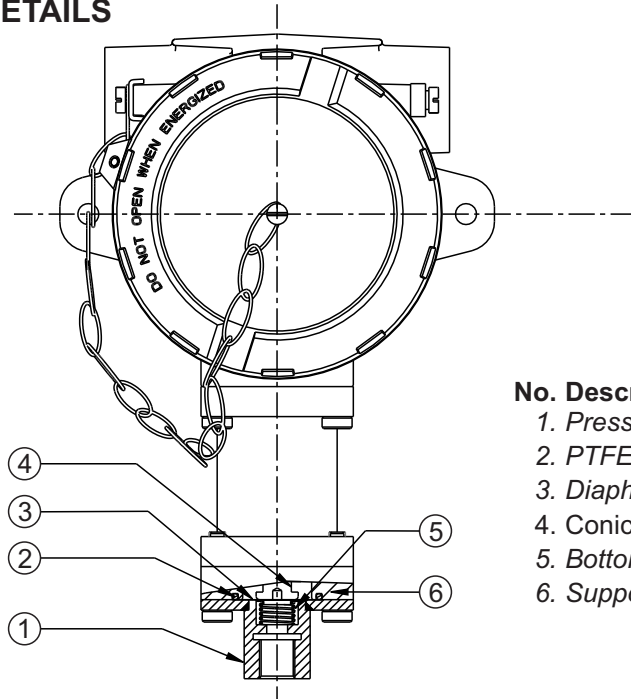

PRESSURE CAPSULE DETAILS



- No. Description**
1. Pressure Housing
 2. PTFE O-Ring
 3. Diaphragm
 4. Conical Plunger
 5. Bottom Spring
 6. Support Plate

Note : *wetted parts* are mentioned in italics.

INSTALLATION DRAWING

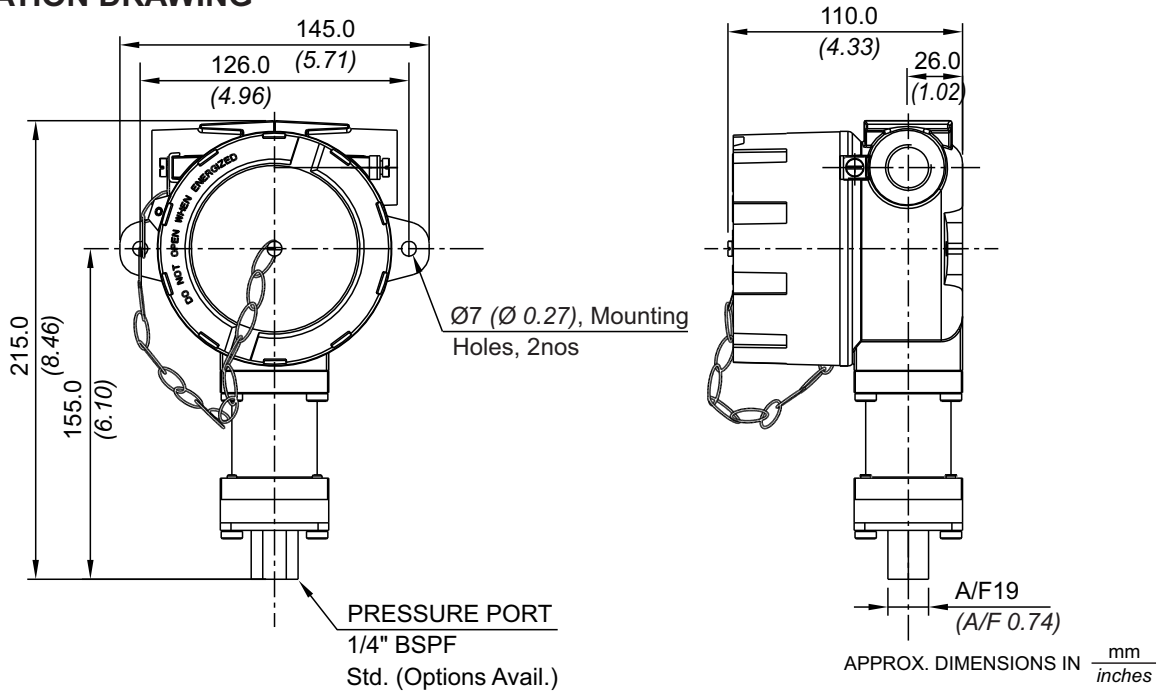

FR HIGH RANGE COMPOUND SWITCHES

RANGE SELECTION TABLE

| Range Code | Range bar (psi) | Differential* bar (psi) | Maximum Working Pressure bar (psi) |
|------------|--------------------------------|--|------------------------------------|
| | | Approximate Maximum for "A1" microswitch | |
| C01 | -1 to 1.0 (-14.50 to 14.50) | 0.15 (2.17) | 12.0 (174.05) |
| C02 | -1 to 1.5 (-14.50 to 21.75) | 0.2 (2.90) | 12.0 (174.05) |
| C03 | -1 to 2.6 (-14.50 to 37.71) | 0.3 (4.35) | 12.0 (174.05) |
| C04 | -1 to 3.6 (-14.50 to 52.21) | 0.4 (5.80) | 12.0 (174.05) |
| C07 | -1 to 7 (-14.50 to 101.53) | 0.8 (11.603) | 12.0 (174.05) |

Note:

1. The minimum differential increases with the setpoint. The differential values mentioned in the above table are approximate maximum for FSR. The differential value will vary according to the pressure range selected and microswitch type. For actual values of differential please contact sales office.

2. When using 2SPDT switching arrangement, both microswitches may not actuate and/or deactuate at the same point. A small stage gap, normally upto +/- 5% FSR (depending on range code) may be observed. The On-Off differential (hysteresis) typically tends to be atleast double of those published for 1SPDT pressure switches.

If actuation and/or deactuation at same point is critical part of operation, then it can be achieved by using a separate DPDT relay. This relay will need a separate power supply for it's coil.

Intrinsic Safety (Exia) : Pressure and temperature switches are classified as simple apparatus, as per IEC 60079-11, as they neither store or generate energy. Hence switches can be used in intrinsically safe systems provided the power source is IS certified. Because of low voltages and current it is recommended to use hermetically sealed microswitches / microswitches.

HOW TO ORDER FLAMEPROOF COMPOUND RANGE SWITCHES

| Group 1 | Group 2 | Group 3 | Group 4 | Group 5 | Group 6 | Group 7 | Group 8 | | | | | | | | |
|--|------------------|------------------|-------------|----------------------------|------------------|-------------------------------|-----------|-------|---|--|---|---|--|--|--|
| Non standard allocation | Model | Cable Entry Size | Switch Type | Range Code (values in bar) | Microswitch Type | Pressure Port Material / Size | Diaphragm | | | | | | | | |
| <p><input type="checkbox"/> A prefix "N" is used in the model code in case of any non standard options / accessories that are provided with the switches. Will be given by manufacturer, only after agreement of supply details with customer.</p> <p>The prefix is subject to change as per specific requirement.</p> <p>Approx. switch weight in Kgs</p> <table border="1"> <tr> <td>Enclosure</td> <td>FR</td> </tr> <tr> <td>Aluminium</td> <td>2.110</td> </tr> <tr> <td>Grey CI</td> <td>4.520</td> </tr> <tr> <td>SS</td> <td>4.610</td> </tr> </table> | Enclosure | FR | Aluminium | 2.110 | Grey CI | 4.520 | SS | 4.610 | <p>FR = Flameproof pressure switch, EAC approved</p> | <p>1 = Al. head 1/2" NPT threads 2 = Al. head 3/4" NPT threads 3 = Al. head M20 x 1.5 threads *4 = Grey CI head 1/2" NPT threads *5 = Grey CI head 3/4" NPT threads *6 = Grey CI head M20 x 1.5 threads 7 = SS head 1/2" NPT threads 8 = SS head 3/4" NPT threads 9 = SS head M20 x 1.5 threads</p> | <p>C1 = compound switch, fixed differential without scale</p> <p>For adjustable differential please select microswitch A6 in group 6</p> | <p>C01 = (-1 to 1.0) C03 = (-1 to 2.6) C04 = (-1 to 3.6) C07 = (-1 to 7.0)</p> | <p>A1 = General purpose microswitch rated at 15 A, 250 VAC *A6 = elements with adjustable deadband *A7 = 2SPDT switching elements A8 = General purpose microswitch rated at 5 A, 250 VAC; 5 A, 28 VDC B1 = Low differential microswitch rated at 15 A, 250 VAC; 5 A, 28 VDC</p> <p>Please refer to page nos. 120 & 121 for options and specifications of microswitches * Please contact sales office for additional information Please check the note under Range Selection Table for Exi applications.</p> | <p>S1 = SS316 / 1/4" BSP(F) S2 = SS316 / 1/4" NPT(F)</p> <p>More options available, please contact sales office</p> | <p>*0 = Neoprene *1 = PTFE 2 = SS 316L</p> <p>*In case of non-metallic diaphragms the ambient temperature range should be (-20° to 60° C.</p> |
| Enclosure | FR | | | | | | | | | | | | | | |
| Aluminium | 2.110 | | | | | | | | | | | | | | |
| Grey CI | 4.520 | | | | | | | | | | | | | | |
| SS | 4.610 | | | | | | | | | | | | | | |

eg. A flameproof switch for gas group IIC, with 1/2" NPT cable entry in aluminium housing as 1SPDT pressure switch, having -1 bar to +1 bar pressure range, with 15Amp. microswitch, SS316 pressure housing with 1/4" BSP port size & Neoprene diaphragm shall be specified by

| Group 1 | Group 2 | Group 3 | Group 4 | Group 5 | Group 6 | Group 7 | Group 8 |
|--------------------------|---------|---------|---------|---------|---------|---------|---------|
| <input type="checkbox"/> | FR | 1 | C1 | C01 | A1 | S1 | 0 |

Please specify full model number to avoid ambiguity. If only the first two groups are specified while ordering, uncalibrated switches with standard wetted parts and enclosures will be supplied.